

Project \_\_\_\_\_  
 Item \_\_\_\_\_  
 Quantity \_\_\_\_\_  
 CSI Section 11400  
 Approved \_\_\_\_\_  
 Date \_\_\_\_\_

## Master Series Gas XPress Grill With Active Compression

### Models

- XPG24AC



Model XPG24AC  
Shown with low-profile grease cans



Example of NEMA 30A  
90 degree plug

### Standard Features

- Programmable control for each cooking lane precisely controls:
  - Automatic lifting and lowering of upper platen
  - Cooking gap and time
- EasyTouch™ screen design is simple and intuitive with Press and Go interface
- Advanced temperature control, smart anticipation versus on-off:
  - Eliminates temperature overshoot and undershoot
  - Increases temperature uniformity with five independently controlled heat zones - three on lower plate and two on upper platen
  - Each lane can be set to a different temperature for menu flexibility, e.g., all-day breakfast
  - Each lane can be turned off when not required - saving energy
- Recipes are programmed by setting grill temperature, platen temperature, cook time.
- Option to choose a maximum 1-inch or 2-inch cook gap:
  - 1-inch cook gap:
    - Cook food product up to 1 inch thick
    - Maximum platen opening angle is 50 degrees
  - 2-inch cook gap:
    - Cook food product up to 2 inches thick
    - Maximum platen opening angle is 42 degrees

### Optional

- Universal Tool Holder (1 or 2)
- UHC tray holder

### Specifications

The XPress Grill's upper and lower grill plates cook both sides simultaneously, reducing cook times by up to 50%. Upper grill plate is automatically raised and lowered by a lift system powered by a quiet actuator.

Lower griddle plate made of 3/4" (19mm) thick carbon steel, machine ground and highly polished.

Lower grill plate heated by one electric heating element and two gas burners.

Upper platen heated by nickel plated cast aluminum electric heating elements.

Electric top heater provided with replaceable quick release Teflon sheets.

Available in three phase power for Delta or Wye electrical systems.

Voltage sensing detects brownouts and electrical input

issues. Power calibration feature adjusts power output based on electrical system voltage.

Available with CSA approvals for natural or propane gas.

Available with CE approvals for G20, G25, G25.3, G30, and G31 gas.

All have NSF approval.

Installation with zero clearance against non-combustible surfaces.

Grill can be installed at high elevation (4,501 - 12,000 ft). Be sure to specify installation elevation when ordering.

**NOTE:** Grills supplied with casters and installed with flexible gas hose must be installed with an approved restraining device.



Master Series Gas XPress Grill With Active Compression

## Master Series Gas XPress Grill With Active Compression

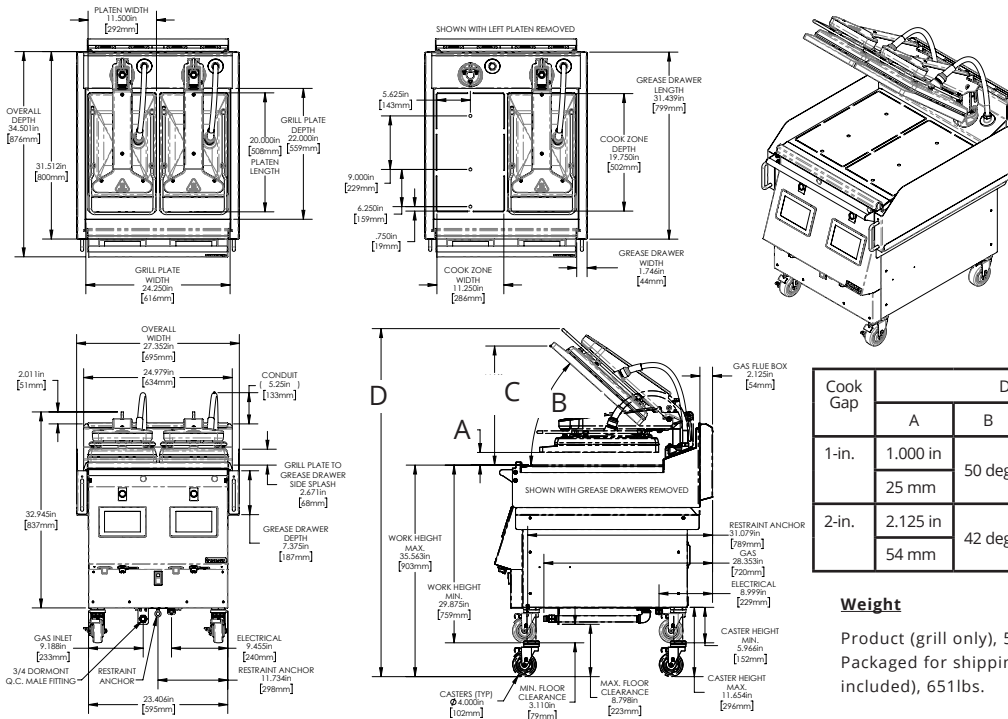

Cook Gap	Dimension			
	A	B	C	D
1-in.	1.000 in	50 deg	23.009 in	61.267 in
	25 mm		584 mm	1556 mm
2-in.	2.125 in	42 deg	20.018 in	58.507 in
	54 mm		508 mm	1486 mm

### Weight

Product (grill only), 586lbs.  
Packaged for shipping (accessories included), 651lbs.

1-Input - Electrical Input Specification - North America, Central America, and South America					
CSA Approved Models					
Model	Volts 3Ph (DELTA) 50/60 Hz	Total Current (A)			Power (kW)
		L1	L2	L3	
XPG24AC 2 Platen	200V	19.9	17.3	27.4	7.0
	208V	19.6	16.9	26.9	7.1
	220V	18.2	15.3	24.7	6.9
	230V	17.5	14.4	23.6	6.9
	240V	17.5	14.1	23.4	6.9

1-Input - Electrical Input Specification - Exports					
CE Approved Models					
Model	Volts 3Ph (WYE) 50/60 Hz	Total Current (A)			Power (kW)
		L1	L2	L3	
XPG24AC 2 Platen	220V/380V	4.7	12.6	16.3	6.9
	230V/400V	4.7	11.8	15.8	6.9
	240V/415V	4.7	11.8	15.8	6.9

Cords - Exports - WYE		
Country	Factory Installed	Plug Options
Various	Yes	IEC 32A Pin & Sleeve

Cords - The Americas - DELTA		
Country	Factory Installed	Plug Options
USA	Yes	NEMA 30A. right angle
Canada	Yes	NEMA 30A. right angle
Other	No	Customer Provided

For pin & sleeve plug, order installation kit

Gas Specifications for CSA Approved Models - The Americas			
Gas Type	Total Input	Supply Pressure	Manifold Pressure
	BTU	"W.C.	W.C.
Natural Gas	48,000	7.0	4.0
Propane	46,000	11.0	4.0

Valid for units installed up to 4,500 feet (1,372 meters) above sea level.

Gas Specifications for CE Approved Models - Exports				
Gas Type	Group	Total Input	Supply Pressure	Manifold Pressure
		kW	mbar	mbar
G20 Natural Gas	H, E	6.4	20/25	10.0
G25 Natural Gas	L, LL, E	6.4	20/25	13.7
G25.3 Natural Gas	K	6.4	20/25	13.7
G31 Propane	P	6.8	30/37/50	10.0
G30 Butane	B	7.0	30	8.7
G30/31 LPG	B/P	7.0	30/50	8.7

Garland reserves the right to make changes to the design or specifications without prior notice.

Garland Commercial Ranges Ltd.  
1177 Kamato Road,  
Mississauga, Ontario  
L4W 1X4 CANADA

General Inquires 1-905-624-0260  
USA Sales, Parts and Service 1-800-424-2411  
Canadian Sales 1-888-442-7526  
Canada or USA Parts/Service 1-800-427-6668

www.garland-group.com  
8062D  
12/25

