

Project _____
 Item _____
 Quantity _____
 CSI Section 11400
 Approved _____
 Date _____

Master Series Electric XPress Grill With Active Compression

Models

- XPE36AC



Model XPE36AC



Example of NEMA 50A 90 degree plug

Standard Features

- Programmable control for each cooking lane precisely controls:
 - Automatic lifting and lowering of upper platen
 - Cooking gap and time
- EasyTouch™ screen design is simple and intuitive with Press and Go interface
- Advanced temperature control, smart anticipation versus on-off:
 - Eliminates temperature overshoot and undershoot
 - Increases temperature uniformity with five independently controlled heat zones - three on lower plate and two on upper platen
 - Each lane can be set to a different temperature for menu flexibility, e.g., all-day breakfast
 - Each lane can be turned off when not required - saving energy
- Recipes are programmed by setting grill temperature, platen temperature, cook time.
- Option to choose a maximum 1-inch or 2-inch cook gap:
 - 1-inch cook gap:
 - Cook food product up to 1 inch thick
 - Maximum platen opening angle is 50 degrees
 - 2-inch cook gap:
 - Cook food product up to 2 inches thick
 - Maximum platen opening angle is 42 degrees
- Allowable active compression cooking
- USB interface to update menus
- User interface provides advanced diagnostics and error logging for ease of service and increased first-time fix
- Stainless steel front, top and sides
- Towel bar with bun pan lip
- Stainless steel dual side grease collectors
- Splash guards
- Swivel casters (4) with front brakes
- Hatchless cowl for protection from water during cleaning
- IPX4 water resistant rating
- Two year limited parts and labor (USA & Canada)
- Cleaning kit with high temperature grill cleaner and cleaning tools/ accessories, provided with every grill.

Optional

- Universal Tool Holder (1 or 2)
- UHC tray holder

Specifications

The XPress Grill's upper and lower grill plates cook both sides simultaneously, reducing cook times by up to 50%.

Upper grill plate is automatically raised and lowered by a lift system powered by a quiet actuator.

Lower griddle plate made of 3/4" (19mm) thick carbon steel, machine ground and highly polished.

Lower grill plate heated by three electric heating elements.

Upper platen heated by nickel-plated cast aluminum electric heating elements.

Electric top heater provided with replaceable quick release Teflon sheets.

Available in three phase power for Delta or Wye electrical systems.

Voltage sensing detects brownouts and electrical input issues. Power calibration feature adjusts power output based on electrical system voltage.

Available with CSA or CE approvals.

All have NSF approval.

Installation with zero clearance against non-combustible surfaces.



Master Series Electric XPress Grill With Active Compression

Master Series Electric XPress Grill With Active Compression

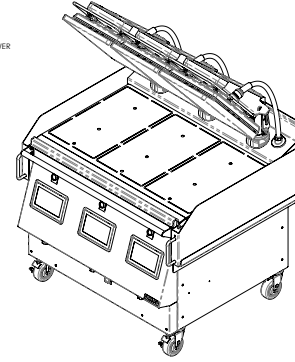
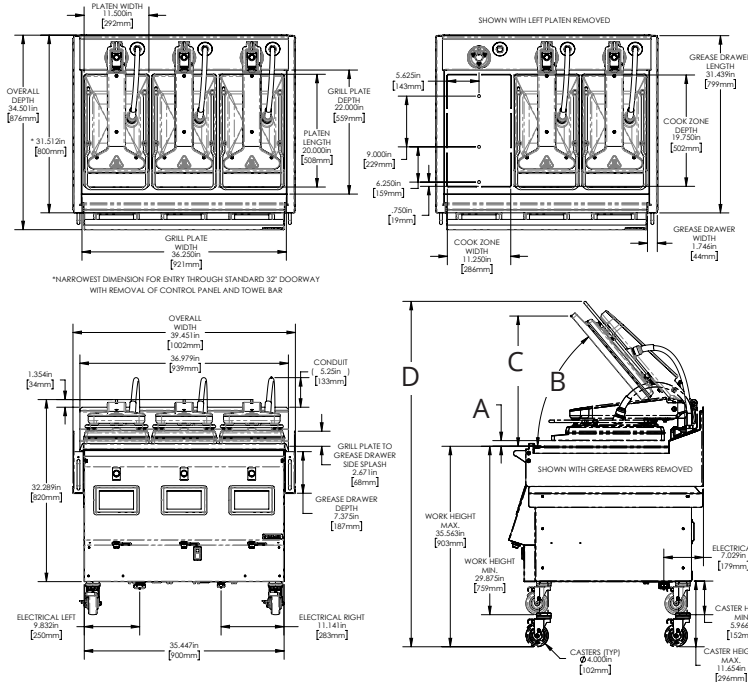

Cook Gap	Dimension			
	A	B	C	D
1-inch	1.000 in	50 deg	23.009 in	61.267 in
	25 mm		584 mm	1556 mm
2-inch	2.125 in	42 deg	20.018 in	58.507 in
	54 mm		508 mm	1486 mm

Weight
 Product (grill only), 751lbs.
 Packaged for shipping (accessories included), 865lbs.

2-Inputs - Electrical Input Specification - North America, Central America, and South America					
CSA Approved Models					
Model	Volts 3Ph (DELTA) 50/60 Hz	Total Current (A)			Power (kW)
		L1	L2	L3	
XPE36AC 3 Platen Cord 1	200V	47.3	47.8	47.8	16.0
	208V	43.0	43.1	43.1	15.2
	220V	42.0	42.2	42.2	15.8
	230V	40.1	40.3	40.3	15.9
XPE36AC 3 Platen Cord 2	240V	40.0	39.8	39.8	15.9
	200V	26.6	24.7	23.1	8.0
	208V	23.9	22.8	21.3	7.6
	220V	24.0	22.6	21.4	7.9
XPE36AC 3 Platen Cord 2	230V	23.1	22.0	21.0	7.9
	240V	22.5	21.8	21.0	7.9

1-Input - Electrical Input Specification - Exports					
CE Approved Models					
Model	Volts 3Ph (WYE) 50/60 Hz	Total Current (A)			Power (kW)
		L1	L2	L3	
XPE36AC 3 Platen	220V/380V	36.8	36.8	37.1	23.7
	230V/400V	34.9	34.9	35.2	23.9
	240V/415V	33.6	33.6	33.9	23.9

2-Inputs - Electrical Input Specification - Exports					
CE Approved Models					
Model	Volts 3Ph (WYE) 50/60 Hz	Total Current (A)			Power (kW)
		L1	L2	L3	
XPE36AC 3 Platen Cord 1	220V/380V	15.5	13.8	12.6	7.9
	230V/400V	15.3	13.8	11.8	8.0
	240V/415V	15.0	13.8	11.8	8.0
XPE36AC 3 Platen Cord 2	220V/380V	24.9	26.7	25.0	15.8
	230V/400V	23.9	26.0	23.4	15.9
	240V/415V	22.9	25.5	22.9	15.9

Cords - The Americas - DELTA		
Country	Factory Installed	Plug Options
USA	Yes	(1) NEMA 30A & (1) NEMA 50A, right angle (2) NEMA 50A, right angle
Canada	No	No cord
Other	No	Customer Provided

For pin & sleeve plug, order installation kit

Cords - Exports - WYE		
Country	Factory Installed	Plug Options
Various	Yes	IEC 63A Pin & Sleeve 2x IEC 32A Pin & Sleeve

3-Inputs - Electrical Input Specification - Exports					
CE Approved Models					
Model	Volts 3Ph (WYE) 50/60 Hz	Total Current (A)			Power (kW)
		L1	L2	L3	
XPE36AC 3 Platen Cord 1	220V/380V	15.5	13.8	12.6	7.9
	230V/400V	15.3	13.8	11.8	8.0
	240V/415V	15.0	13.8	11.8	8.0
XPE36AC 3 Platen Cord 2	220V/380V	12.6	15.5	13.8	7.9
	230V/400V	11.8	15.3	13.8	8.0
	240V/415V	11.8	15.0	13.9	8.0
XPE36AC 3 Platen Cord 3	220V/380V	13.8	12.6	15.8	7.9
	230V/400V	13.8	11.8	15.6	8.0
	240V/415V	13.9	11.8	15.3	8.0

Garland reserves the right to make changes to the design or specifications without prior notice.

Garland Commercial Ranges Ltd.
 1177 Kamato Road,
 Mississauga, Ontario
 L4W 1X4 CANADA

General Inquires 1-905-624-0260
 USA Sales, Parts and Service 1-800-424-2411
 Canadian Sales 1-888-442-7526
 Canada or USA Parts/Service 1-800-427-6668

www.garland-group.com
 8032D
 06/25

