

## Master Series Electric XPress Grill

Project \_\_\_\_\_  
 Item \_\_\_\_\_  
 Quantity \_\_\_\_\_  
 CSI Section 11400  
 Approved \_\_\_\_\_  
 Date \_\_\_\_\_

Master Series Electric XPress Grill

### Models

- XPE36



Model XPE36  
Shown with low-profile grease cans



Example of NEMA 30A  
90 degree plug

### Standard Features

- Programmable control for each cooking lane precisely controls:
  - Automatic lifting and lowering of upper platen
  - Cooking gap and time
- EasyTouch™ screen design is simple and intuitive with Press and Go interface
- Advanced temperature control, smart anticipation versus on-off
  - Eliminates temperature overshoot and undershoot
  - Increases temperature uniformity with five independently controlled heat zones - three on plate and two on platen
  - Each lane can be set to a different temperature for menu flexibility, eg., all-day breakfast
  - Each lane can be turned Off when not required -- saving energy
- Recipes are programmed by setting grill temperature, platen temperature, cooking gap up to 2 inches (5 cm) and cook time
- USB interface to update menus
- User interface provides advanced diagnostics and error logging for ease of service and increased first-time fix

- Stainless steel front, top and sides
- Towel bar with bun pan lip
- Stainless steel dual side grease collectors
- Splash guards
- Swivel casters (4) with front brakes
- Hatchless cowl for protection from water during cleaning
- IPX4 water resistant rating
- Two-year limited parts and labor (USA & Canada)
- Cleaning kit with high temperature grill cleaner and cleaning tools/ accessories, provided with every grill.

### Optional Accessories

- Universal Tool Holder (1 or 2)
- UHC tray holder

### Specifications

The XPress Grill's upper and lower grill plates cook both sides simultaneously, reducing cook times by up to 50%. Upper grill plate is automatically raised and lowered by a lift system powered by a quiet actuator.

Lower griddle plate made of 3/4" (19mm) thick carbon steel, machine ground and highly polished.

Lower grill plate heated by three electric heating elements.

Upper platen heated by nickel plated cast aluminum electric heating elements.

Electric top heater provided with replaceable quick release Teflon sheets. Available in three phase power for Delta or Wye electrical systems.

Voltage sensing detects brownouts and electrical input issues. Power calibration feature adjusts power output based on electrical system voltage.

Available with CSA or CE approvals.

All have NSF approval.

Installation with zero clearance against non-combustible surfaces.



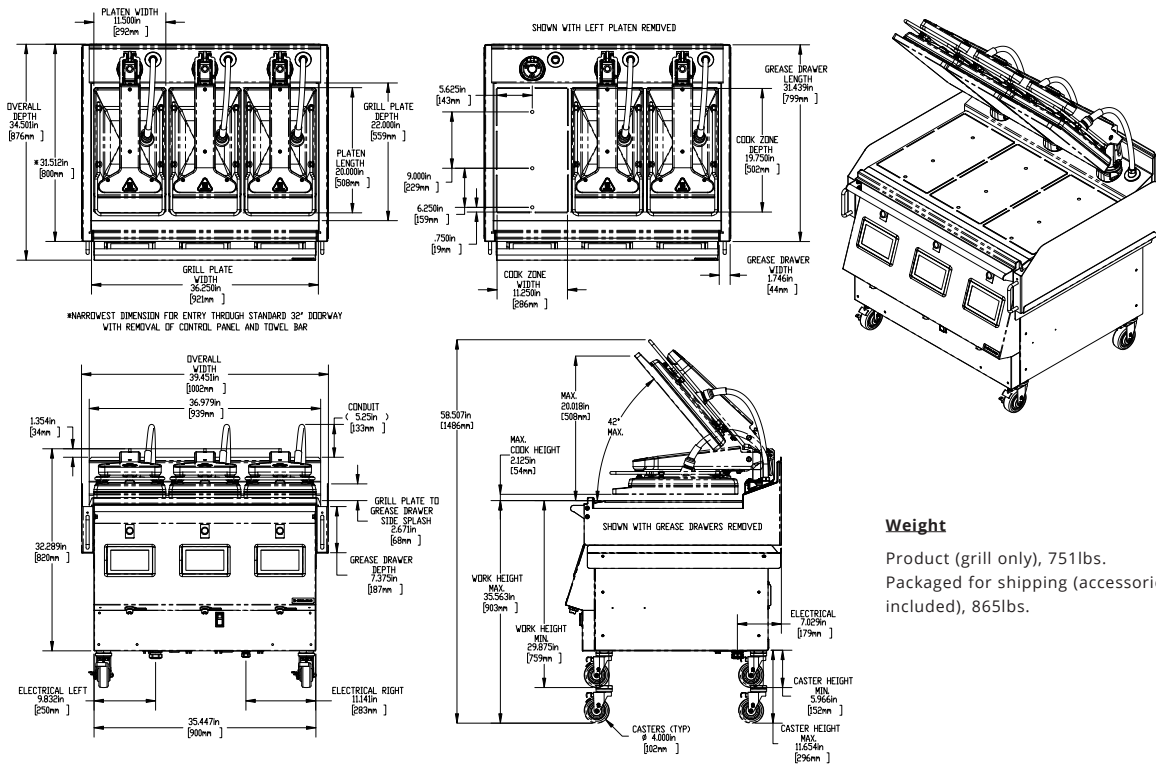

### Weight

Product (grill only), 751lbs.  
Packaged for shipping (accessories included), 865lbs.

2-Inputs - Electrical Input Specification - North America, Central America, and South America					
CSA Approved Models					
Model	Volts 3Ph (DELTA) 50/60 Hz	Total Current (A)			Power (kW)
		L1	L2	L3	
XPE36 3 Platen Cord 1	200V	47.3	47.8	47.8	16.0
	208V	43.0	43.1	43.1	15.2
	220V	42.0	42.2	42.2	15.8
	230V	40.1	40.3	40.3	15.9
XPE36 3 Platen Cord 2	200V	26.6	24.7	23.1	8.0
	208V	23.9	22.8	21.3	7.6
	220V	24.0	22.6	21.4	7.9
	230V	23.1	22.0	21.0	7.9
	240V	22.5	21.8	21.0	7.9

1-Input - Electrical Input Specification - Exports					
CE Approved Models					
Model	Volts 3Ph (WYE) 50/60 Hz	Total Current (A)			Power (kW)
		L1	L2	L3	
XPE36 3 Platen	220V/380V	36.8	36.8	37.1	23.7
	230V/400V	34.9	34.9	35.2	23.9
	240V/415V	33.6	33.6	33.9	23.9

Cords - Exports - WYE		
Country	Factory Installed	Plug Options
Various	Yes	IEC 63A Pin & Sleeve
		2x IEC 32A Pin & Sleeve
		3x IEC 32A Pin & Sleeve

Cords - The Americas - DELTA		
Country	Factory Installed	Plug Options
USA	Yes	(1) NEMA 30A & (1) NEMA 50A, right angle
		(2) NEMA 50A, right angle
Canada	No	No cord
Other	No	Customer Provided

For pin & sleeve plug, order installation kit

Garland reserves the right to make changes to the design or specifications without prior notice.

Garland Commercial Ranges Ltd.  
1177 Kamato Road,  
Mississauga, Ontario  
L4W 1X4 CANADA

General Inquires 1-905-624-0260  
USA Sales, Parts and Service 1-800-424-2411  
Canadian Sales 1-888-442-7526  
Canada or USA Parts/Service 1-800-427-6668

www.garland-group.com  
8060D  
06/25

