

Vertical Contact Toaster | VCT-2000



GOLDEN BROWN FINISH

The Vertical Contact Toaster VCT-2000 is a staple in the foodservice operations with a reputation for quality, performance and reliability around the world.

The Vertical Contact Toaster gives buns a consistent, golden brown finish which helps the sandwich stay firm and delicious. Additional products for the unit include a wide mouth bun feeder, motorized butter wheel, heated base, and back plate. The VCT-2000 features a digital controller for making precise adjustments to the quality of the toast for different bread products.



VCT-2000 Vertical Contact Toaster



Dual-Sided Platen

Vertical Contact Toaster has more capacity than conventional single-sided toasters, allowing operators to quickly serve fresh products



Minimal Bun Marking

Forget burnt buns. Our belt wraps minimize marking of the buns for perfect a golden finish.



Small Footprint

The upright design saves valuable counter space, allowing it to easily integrate into any operation

Vertical Contact Toaster | VCT-2000

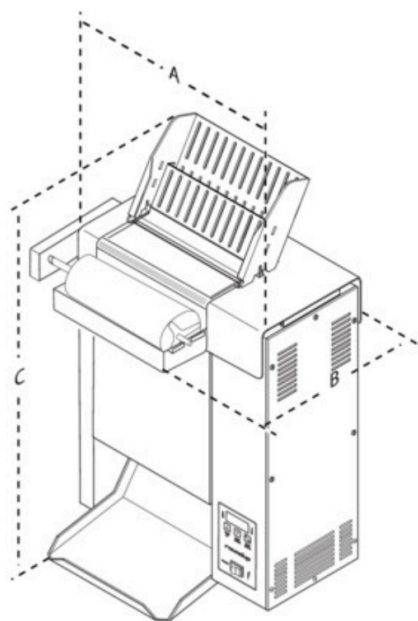

Features:

- Auxiliary heater warms top side of buns
- Space-saving vertical design
- Continuously moving conveyor for immediate toasting
- Separate compression adjustments for the heel and the crown
- Release sheets allow buns to move easily down the heated platen without sticking or slipping
- Easy to operate and clean
- Stainless steel construction
- Available toasting times range from 10 to 28 seconds
- Additional products available: wide mouth bun feeder, butter wheel and heated base

VCT-2000

Electrical Ratings

Dimensions

Model & Mfg. No.	Capacity*	Approvals	Plug	Volts	Watts	Amps	Hz.	Width (A)	Depth (B)	Height (C)	Shipping Weight
VCT-2000 9210100	10-sec. toast time		NEMA 6-20P	208	3291	15.8	50/60	21 1/4" (540 mm)	10 3/4" (273 mm)	23 1/4" (591 mm)	75 lbs. (34 kg)
VCT-2000 9210200	10-sec. toast time		CEE 7/7	220-240	3019-3593	13.7-15	50/60	22 1/4" (565 mm)	10 3/4" (273 mm)	23 1/4" (591 mm)	88 lbs. (39.9 kg)
VCT-2000 9210987	10-sec. toast time		IEC-309	230	3019-3593	13.7-15	50/60	21 1/4" (540 mm)	15 1/4" (387 mm)	23 1/4" (591 mm)	88 lbs. (39.9 kg)
VCT-2000 9210217	17-sec. toast time		CEE 7/7	220-240	3019-3593	12-17.5	50/60	22 1/4" (565 mm)	15 1/4" (387 mm)	23 1/4" (591 mm)	76 lbs. (34.5 kg)



VCT-2000

VCT-2000 (with heated base)

VCT-2000 9210300	10-sec. toast time		NEMA 6-20P	208	3326	16	50/60	21 1/4" (540 mm)	10 3/4" (273 mm)	23 1/4" (591 mm)	85 lbs. (38.6 kg)
VCT-2000 9210400	10-sec. toast time		CEE 7/7	220-240	3058-3640	13.9-15.2	50/60	22 1/4" (565 mm)	22 1/4" (565 mm)	23 1/4" (591 mm)	88 lbs. (39.9 kg)
VCT-2000 9210402	10-sec. toast time		IEC-309	220-240	3058-3640	13.9-15.2	50/60	22 1/4" (565 mm)	22 1/4" (565 mm)	23 1/4" (591 mm)	88 lbs. (39.9 kg)



VCT-2000 with Heated Base

VCT-2000 (with heated base and back plate)

VCT-2000 9210304	10-sec. toast time		NEMA 6-20P	208	3326	16	50/60	21 1/4" (540 mm)	10 3/4" (273 mm)	23 1/4" (591 mm)	88 lbs. (39.9 kg)
------------------	--------------------	--	------------	-----	------	----	-------	------------------	------------------	------------------	-------------------



VCT-2000 with Heated Base and Back Plate

*Toast time will vary depending on power frequency

Vertical Contact Toaster | VCT-2000

VCT-2000 (with wide mouth)

Model & Mfg. No.	Capacity*	Approvals	Plug	Volts	Watts	Amps	Hz.	Width (A)	Depth (B)	Height (C)	Shipping Weight
VCT-2000 9210116	10-sec. toast time		NEMA 6-20P	208	3291	15.8	60	21 1/4" (540 mm)	10 3/4" (273 mm)	23 1/4" (591 mm)	88 lbs. (39.9 kg)
VCT-2000 9210121	17-sec. toast time		NEMA 6-20P	208	3291	15.8	60	21 1/4" (540 mm)	10 3/4" (273 mm)	23 1/4" (591 mm)	85 lbs. (38.6 kg)
VCT-2000 9210201	23-sec. toast time		CEE 7/7	220-240	3019-3593	13.7-15	50	22 1/4" (565 mm)	10 3/4" (273 mm)	23 7/32" (590 mm)	88 lbs. (39.9 kg)
VCT-2000 9210203	17-sec. toast time		CEE 7/7	220-240	3019-3593	13.7-15	50	22 1/4" (565 mm)	10 3/4" (273 mm)	23 1/4" (591 mm)	88 lbs. (39.9 kg)
VCT-2000 9210123	28-sec. toast time		NEMA 6-20P	208	3291	15.8	60	21 1/4" (540 mm)	10 3/4" (273 mm)	23 1/4" (591 mm)	85 lbs. (38.6 kg)
VCT-2000 9210124	17-sec. toast time		NEMA 6-20P	208	3291-4545	15.8-18.9	60	21 1/4" (540 mm)	15 1/4" (387 mm)	24 1/4" (616 mm)	88 lbs. (39.9 kg)
VCT-2000 9210212	10-sec. toast time		CEE 7/7	220-240	3019-3593	13.7-15	50/60	22 1/4" (565 mm)	10 3/4" (273 mm)	23 7/32" (590 mm)	88 lbs. (39.9 kg)



VCT-2000 with Wide Mouth



VCT-2000 with Butter Wheel

VCT-2000 (with motorized butter wheel)

VCT-2000 9210114	10-sec. toast time		NEMA 6-20P	208	3291	15.8	50/60	21 1/4" (540 mm)	15 1/4" (387 mm)	23 1/4" (591 mm)	92 lbs. (41.7 kg)
VCT-2000* 9210118	17-sec. toast time		NEMA 6-20P	208	3291	15.8	50/60	21 1/4" (540 mm)	15 1/4" (387 mm)	23 1/4" (591 mm)	92 lbs. (41.7 kg)

VCT-2000 (with wide mouth and motorized butter wheel)

VCT-2000 9210114	10-sec. toast time		NEMA 6-20P	208	3291	15.8	50/60	21 1/4" (540 mm)	15 1/4" (387 mm)	23 1/4" (591 mm)	92 lbs. (41.7 kg)
------------------	--------------------	--	------------	-----	------	------	-------	------------------	------------------	------------------	-------------------

*Toast time will vary depending on power frequency

Vertical Contact Toaster Accessories

Item	Mfg. No.	Description	For Use With
Butter Wheel	7000703	Stainless steel butter wheel and pan. Use to butter buns before toasting. Attaches to the top of the toaster without the use of tools and can be removed easily for cleaning.	VCT-25, 50, 1000 & 2000
Universal Tall Bun Feeder	7001522	Automatic gravity-fed bun feeder for pre-loading buns into a toaster, which increases productivity by allowing operator to complete other duties. Attaches to the top of the toaster without the use of tools and adjustable to fit most bun sizes.	VCT-25, 50, 1000 & 2000
Universal Tall Angled Bun Feeder	7001523	Angled, automatic gravity-fed bun feeder for pre-loading buns into a toaster, which increases productivity by allowing operator to complete other duties. Attaches to the top of the toaster without the use of tools and adjustable to fit most bun sizes.	VCT-25, 50, 1000 & 2000
Low Profile Universal Bun Feeder	7001521	Low profile bun feeder allows for quick and easy loading of buns into the toaster. Attaches to the top of the toaster without the use of tools.	VCT-25, 50, 1000 & 2000
Cleaning Tool Kit	7001126	Aluminum handle with attachable cleaning pad for cleaning platens of contact toasters	All VCT models
HLZ-1 Heated Landing Zone	7000685	Heated landing zone keeps freshly toasted buns warm until they are ready to serve. Attaches easily to the bottom of the toaster without the use of tools. (120 volts, 35 Watts, 0.3 Amp., 50/60 Hz. NEMA 5-15P Plug)	VCT-25, 50, 1000 & 2000
HLZ-1 Heated Landing Zone	7000842	Heated landing zone keeps freshly toasted buns warm until they are ready to serve. Attaches easily to the bottom of the toaster without the use of tools. (230 volts, 35 Watts, 0.3 Amp., 50/60 Hz. CEE 7/7 Plug)	VCT-25, 50, 1000 & 2000
Damper Kit	7000574	Covers keep heat contained in the toaster to save energy. When used, toasters consume half as much energy in the idle state, use 22% less energy when cooking, and give off half as much average heat gain to space.	VCT-25, 50, 1000 & 2000